

# Wet Location Emergency Light

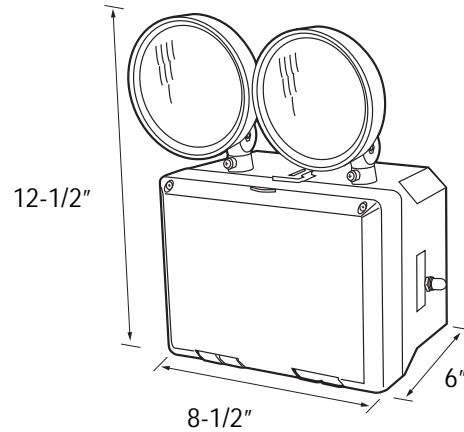

Dimensions:



## 100312 Series

### Standard Features:

#### HOUSING

- ▶ ABS, corrosion-resistant UV stabilized enclosure.
- ▶ Wet location listed.
- ▶ Water-tight, rain-tight, corrosion and dust resistant.
- ▶ Suitable for use in damp and wet locations.
- ▶ Certified by ETL to UL924 standards.
- ▶ Meets NFPA Life Safety 101, OSHA, NEC local and state codes.

#### MOUNTING

- ▶ 100312 Series emergency lights are designed to mount to walls with four 1/4" integral mounting holes in the unit housing.
- ▶ Mounting hardware provided.
- ▶ Housings are easily drilled or punched to accept sealed conduit hubs.

### Electrical Features:

#### ELECTRICAL

- ▶ 120/277 VAC dual voltage operation.
- ▶ Sealed momentary test switch.
- ▶ Automatic brownout feature.
- ▶ Solid state charging circuit.
- ▶ Short circuit and overload protection on DC output circuit.
- ▶ Sealed LED indicator light.

#### LAMPS

- ▶ 2 x 7.2 watt incandescent for emergency mode.

#### BATTERY

- ▶ Maintenance-free long life lead calcium battery (6V 10.0Ah) delivers more than 90 minutes capacity to emergency lamps.
- ▶ 24-hour recharge after 90 minute discharge.
- ▶ Low voltage battery disconnection prevents deep discharge damage to the battery.

### Ordering Information:

Item No.	Housing Color
100312	SW: Soft White



#### Globe Lighting

A Devan Industries Co.

2901 Clint Moore Road #229  
Boca Raton, FL 33496

305.777.2388 tel  
561.998.4164 fax

Email: sales@globe-lighting.com  
Web: www.globe-lighting.com